

*For the Operation,
Monitoring, and
Maintenance of a
Gravity On-site
Sewage Treatment
and Disposal System*

HOMEOWNERS'S MANUAL

TABLE OF CONTENTS

Acknowledgments	4
About the authors	4
Foreword	5
Introduction	5
DO'S & DON'TS OF ON-SITE SEWAGE SYSTEM OPERATION	6
MY ON-SITE SYSTEM FILE	8
Property and Permit Facts	9
System Components and Descriptions	10
Monitoring and Maintenance Records and Notes	14
ON-SITE SYSTEM COMPONENTS	17
Operation, Monitoring, Maintenance, and Optional/Improvement Features	17
Source water plumbing and residential water supply plumbing, water meters	17
Drain plumbing, waste water (house sewer lines)	18
Sewer line from residence to septic tank or first component	19
Septic tank	20
Access hatches and risers to tanks	23
In-tank filters and screens	23
Effluent pipes between septic tank(s) and other components	24
Clean-outs	25
Distribution box (D-box)	26
Gravity distribution drainfield	27
Monitoring ports	28
Seepage pit	29
Pump chamber	30
Solids pump	31
Effluent pump	31
Electrical power controls	32
Pump controls, alarms	33
Dosing siphon	34
Curtain drains	35
ON-SITE SYSTEM OPERATION	36
The Water Use Cycle	36
Recreational Vehicle Sewage Tank Dump Facilities Caution	36
Emergency Operation Due to Excessive Water in Drainfield Area	37
Emergency Operation Due to Power Outages	38
APPENDIX A — GLOSSARY	39
APPENDIX B — LAWS AND REGULATIONS	41
APPENDIX C — LIFE CYCLE, ROLES AND RESPONSIBILITIES	42
APPENDIX D — REFERENCES	44

ACKNOWLEDGMENTS

A special thank you to the Cranberry PIE project advisory board, Bill Batstone, Dick Burleigh, Warren Dawes, Al Drouillard, Selden Hall, Frank Hughes, and Jodie Holdcroft for guiding us through not only the creation of the homeowners manual but also the homeowner education courses. Thanks to the Environmental Health Division of the Mason County Health Services Department, the Washington State Department of Health, Environmental Programs, and the Thurston County Environmental Health Division for providing valuable materials and information used to create this manual. We are also indebted to many external reviewers that provided their insight into this manual, Dave Lenning, Rochelle Rothaus, Art Starry, Cindy Bingham, and Dave Tipton. Another special thank you for the Communications staff at the Washington Sea Grant Program for coordinating the production of these documents and insuring that we dotted the I's and crossed the T's.

Puget Sound water quality education activities are funded by the State of Washington through the Office of Marine Environmental and Resource Programs, University of Washington. This publication is funded in part by Grant No. NA76RG0119 to Washington Sea Grant Program from the National Oceanic and Atmospheric Administration (NOAA). Funding is also provided by the Frank Family Foundation and the Public Involvement and Education (PIE) Project, financed by proceeds from the Washington State Water Quality Account, and administered by the Puget Sound Water Quality Action Team.

The views expressed herein are those of the authors and do not necessarily reflect the views of NOAA or any of its sub-agencies.

Washington Sea Grant Marine Advisory Services programs, services and publications are available to all without discrimination.

The mention of trade names, commercial products, or private companies in this publication is for illustration purposes and does not constitute an endorsement by Washington Sea Grant or the University of Washington.

WSG-AS 99-06

www.wsg.washington.edu



ABOUT THE AUTHORS

Charles D. (Don) Leaf served as a continuing education coordinator for the Washington Sea Grant Program Marine Advisory Services during the preparation of this manual. Don has a Bachelors degree in biology from Western Washington University and a Masters of Environmental Studies degree from the Evergreen State College. He is a Registered Sanitarian. Don worked in environmental health with responsibilities in on-site sewage systems as a regulator, project manager, and educator for over 27 years before joining the Washington Sea Grant Program.

Teri King is a marine water quality specialist with Washington Sea Grant Program Marine Advisory Services and has developed and managed on-site sewage education programs in the Puget Sound region. Teri has degrees in Fisheries and Food Sciences from the University of Washington and has written and coauthored a number of publications on fisheries, water quality, and non-point source pollution prevention and remediation. Teri is active in water quality education and shellfish bed restoration.

FOREWORD

We hope that the manual will help you as an owner build and maintain a file of septic system information that will assist you in the operation and monitoring of your gravity on-site sewage system. This collection of information can also help professionals who are hired to perform monitoring or maintenance work on the system. A good permanent record file will also help any other outside or digging contractor to avoid damaging the system.

The manual is not intended to be a technical manual for on-site professionals, but an aid to discussions between professionals and their clients. It is not a substitute for design documents and permit records but a supplement to them.

CDL, April 1999

INTRODUCTION

This manual is intended to help gravity on-site system owners **operate, monitor, and maintain** their system in a more knowledgeable manner. This can help the system function successfully by controlling health hazards and water pollution, as well as helping to prevent expensive repairs.

The manual is tailored to an owner's specific needs — the components that are appropriate for their property. When completed by the homeowner, design records, permits, and installation information is assembled that is unique to their system.

DO'S AND DON'TS OF ON-SITE SYSTEM OPERATION is a set of specific actions that the owner can do and things to avoid that will help the function and life-span of the system.

MY ON-SITE SYSTEM FILE is intended to act as the core file of information that helps the owner operate, monitor, and maintain the system with more knowledge and skill. It will be the basic factual profile of their property and permits, system components and description, monitoring, and maintenance records.

ON-SITE SYSTEM COMPONENTS lists the on-site system components that are found in the owner's system. Each listed component has a section on operation, monitoring, maintenance, and optional/improvement features.

ON-SITE SYSTEM OPERATION describes normal operation and RV dumping as well emergency operations of the system due to heavy rains and power failure.

APPENDIX A. GLOSSARY: terms used in the design, installation, operation, maintenance, and monitoring of on-site sewage systems.

APPENDIX B. LAWS AND REGULATIONS: a brief survey of the rules that apply to on-site systems, their owners, installers, pumpers, designers, and maintenance specialists.

APPENDIX C. ON-SITE SYSTEMS LIFECYCLE, ROLES, AND RESPONSIBILITIES: information about how on-site sewage systems fit into our community and the service providers who perform various functions.

APPENDIX D. REFERENCES: a listing of sources of information used for the production of this manual.

DO'S & DON'TS OF ON-SITE SEWAGE SYSTEM OPERATION

DO THESE THINGS

- ◆ **Control the use of water that generates waste water.** Treatment systems are almost always more effective if operated at or below their intended flow capacity.
- ◆ **Reduce water from showers and baths.** This can be done by installing shower-head flow restrictors, taking shorter showers, or bathing in shallower bath water.
- ◆ **Reduce water use at sinks.** Partially close the supply line valve under the sink.
- ◆ **Fix leaky faucets or a leaky toilet flush valve.** Repair or replace leaky components in toilets and faucets.
- ◆ **Install low-flow toilets.** Old toilets can use 5 to 6 gallons per flush. New toilets use 1.6 gallons or less. Low-flow toilets are now required on all new construction.
- ◆ **Spread laundry throughout the week.** Solids settle better in the septic tank when not given large volumes of water in a single day.
- ◆ **Consider a low-water use washing machine at replacement time or before.** These have improved in the last few years and many appliance dealers have a range of models in stock.
- ◆ **Reduce the discharge of greases and oils.** Scrape plates before washing. Be sure to scrape or wipe grease out of frying pans before washing.
- ◆ **Reduce solids that go to the septic tank, by limiting the use of a kitchen garbage grinder.** Additional solids increase the chances of solids carry-over into the drainfield. Compost kitchen waste, or put it into the garbage. Consider removal of garbage grinders.
- ◆ **Learn your system component locations.** When you know where things are it is easier to protect them.
- ◆ **Divert roof drainage from the drainfield area.** Drainfields function best when the soil under the drainfield is not saturated. Saturated soil can cause drainfield failure and water pollution.
- ◆ **Protect your tank and drainfield from mechanical damage.** Build fences or landscaping barriers that show people that the drainfield is not a parking area.
- ◆ **Create a landscape that is suitable for your septic system.** Proper maintenance of your septic system landscape also helps your system.
- ◆ **Use phosphate-free detergents.** Additional fertilizers harm streams, lakes, ground water, and marine waters.
- ◆ **Build and maintain an information file.** Your file of records can save the details that will be important to a pumper, installer, or other construction professional.
- ◆ **Build and maintain a monitoring and maintenance schedule.** Scheduled expenses are easier to deal with than unscheduled emergencies. Keep the schedule as part of your records.
- ◆ **Keep records.** On-site sewage systems last for a long time. Chances are that you will sell your house and system before it is converted to sewer or the property is abandoned.
- ◆ **Give records or copies of them to the next owner if you sell.** You know more about your system than the future owner. When you buy property, get the septic records from the previous owner.

DON'T DO THESE THINGS

- ◆ **Never put solvents, oil-based paints, or toxic waste down the drain.** Minimize the discharge of water-based or latex paint too. Limit this to brush washing and do not pour excess paint down the drain. Your local household hazardous waste center can take these materials off your hands.
- ◆ **Avoid any types of grease solvent drain cleaner.** Most of these are chlorinated solvents or synthetic solvents that your septic system is not designed to handle. You might also contaminate ground water by using them.
- ◆ **Never use large quantities of acids, bases, or oxidizers to “treat” or “clean” a septic tank.** The proper role of a septic tank is to retain solids and prevent them from being delivered to the drainfield. Solids should be removed by a septic tank pumper.
- ◆ **Don't use more than the recommended quantities of “over the counter” drain cleaners.** These products are oxidizers, bases, or sometimes acids, that will not do significant harm if used in small, label instruction quantity and frequency.
- ◆ **Don't use additives.** Most additives don't work and those that do tend to push solids from the tank toward the drainfield. The drainfield should not receive any additional solids if it can be avoided.
- ◆ **Never drain a hot tub into the system.** This very large quantity of water has the capacity to push solids through the tank without adequate settling.
- ◆ **Never dig without knowing where your system components and water lines are.** Knowing where your system components are can help you avoid costly repairs when digging in your yard.
- ◆ **Don't build any property drains or fix any wet spots without completely knowing how a drain might affect your system.** Many drains have been erroneously installed and have actually caused system failure and pollution.
- ◆ **Don't build structures over your septic system or its components.** Damage to system components may occur. Monitoring and maintenance may become impossible. If you choose to build additions or out-buildings, relocate any on-site system components that would be covered.
- ◆ **Don't pave over your system.** Most system parts are not designed to take traffic weight or compaction. Drainfields depend on air entering through the soil and oxygen dissolved in rainwater. Drainfields also depend on non-compacted soils.
- ◆ **Don't allow cattle or horses, or other pasture animals onto a drainfield area.** Soil compaction and mechanical damage can result.
- ◆ **Don't repair without permits.** Any short term savings could be offset by having the wrong thing repaired or by legal entanglements.
- ◆ **Do Not Flush:**

Coffee grounds	Tampons
Kitty litter	Fats, greases, or oils
Cigarette butts	Wrapping paper
Paper towels	Newspaper
Dental floss	Plastics
Sanitary napkins	Cotton swabs

MY ON-SITE SYSTEM FILE

Taken as a whole, the information that you can assemble relevant and specific to your property will be of great value to you, the on-site system professionals who may be hired to do specific work, and eventually, to a future owner of the property. Once the information is assembled from the various sources, it will act as a core file of information.

This manual often refers to operation, monitoring, and maintenance. The following are examples of these activities.

OPERATION IS:

- ✓ Use of the residence and system.
- ✓ What is put down the drains that lead to the septic system.
- ✓ Decisions about when to do laundry.
- ✓ Decisions about what water-using appliances to buy and use.
- ✓ Kitchen practices including how much grease goes down the drain.
- ✓ Daily variations in use.

MONITORING IS:

- ✓ Observations of the entire on-site system and learning what they mean.
- ✓ Looking at the parts of the system to see if they are working.
- ✓ Measuring solids accumulations in septic tanks or pump chambers
- ✓ Measuring and recording water levels at key locations or observation ports.
- ✓ Calling for or scheduling maintenance based on your observations.
- ✓ Making and keeping records of the system.
- ✓ Knowing how system controls work and observing that they do function.
- ✓ Submitting or having submitted monitoring or maintenance reports to the jurisdictional authority.

MAINTENANCE IS:

- ✓ Routine actions that help keep system components functional.
- ✓ Removing of septage and sludge when necessary.
- ✓ Testing controls and putting them back into correct operation if necessary.
- ✓ Performing the routine or scheduled actions called for in the "Operation and Maintenance Manual" for your system.
- ✓ Adjustments to controls.
- ✓ Replacing or repairing minor components or component parts on an as-needed basis.

PROPERTY AND PERMIT FACTS

A good set of records will help you and the professionals that perform work for you. Records will make monitoring and maintenance less time consuming and save labor costs. Good records make sewage system evaluation easier if you sell your property.

PROPERTY TAX PARCEL NUMBER: _____

additional parcel number (s): _____, _____

any off-property component (s): _____, _____

LEGAL DESCRIPTION: _____

PROPERTY ADDRESS: _____

ORIGINAL ON-SITE SEWAGE SYSTEM (OSS) PERMIT: Application date: _____ Permit No: _____

AS-BUILT DRAWINGS LOCATED: _____

EXPANSION OR REPAIR PERMITS (include structural additions or remodels) (note OSS or building permit type):

Date: _____ Permit No.: _____ To Construct: _____

Date: _____ Permit No.: _____ To Construct: _____

Date: _____ Permit No.: _____ To Construct: _____

Date: _____ Permit No.: _____ To Construct: _____

Date: _____ Permit No.: _____ To Construct: _____

PROPERTY CONSTRUCTION AND SALE TRANSACTIONS RECORDS:

(Optional, but these records may aid in the finding of system information):

Residence Construction Date: _____ Owner: _____ Builder: _____

Sold to: _____ Date: _____

Sold to: _____ Date: _____

Sold to: _____ Date: _____

Sold to: _____ Date: _____

WATER SYSTEM/SOURCE:

Individual Well: Yes _____ No _____ Well records are located: _____

or Multi-service (public) Water System Name: _____

Water System Contact Person: _____

Water System Contact Person Phone: _____

Water System ID Number (if applicable): _____

SYSTEM COMPONENTS AND DESCRIPTIONS

COMPONENTS CHECKLIST

Examine system design or permit records and check components of your system.

- Source water plumbing or residential clean water plumbing, water meters
- Drain plumbing, waste water (house sewer lines)
- Sewer line from residence to septic tank or first component

- Septic tank
- Access hatches and risers to tanks
- In-tank filters and screens
- Effluent pipes between tank(s) and other components
- Clean-outs

- Distribution box
- Gravity distribution drainfield (4-inch pipe systems, even if from pump or siphon)
- Monitoring ports

- Seepage pit

- Curtain drains

If you pump your sewage from the house to the septic tank or the effluent from the tank to the drainfield area:

- Pump chamber
- Solids pump
- Effluent pump
- Electrical power controls
- Pump controls, alarms
- Dosing siphon

SYSTEM DESCRIPTION

SYSTEM DESIGN FLOW _____ gallons per day.

No. of bedrooms: _____

WATER LINE LOCATIONS (include meter and shutoff locations):

SEWER LINE LOCATION

(where line leaves residence and route to first tank):

(Note any crossing of sewer and water lines and method of water line protection such as vertical separation or double casing.)

OFF-PROPERTY LINES

Do effluent lines go onto or across neighboring property or roads? _____

Do easements or property use agreements exist?

Was a Washington State DOT or county road department permit required? _____

Road crossings inspected? _____

Warning signs in place? _____

Other crossings? Streams, other surface water?

SEPTIC TANK

Size (gallons): _____ Size (top dimensions): _____

No. of chambers: _____ Built of: _____

Manufactured by: _____ Installed by: _____

Location of sewer: _____ feet from _____

on _____ side of residence.

Tank inlet: _____ feet from _____

on _____ side of residence.

LOCATION DIAGRAM (draw or attach diagram of all sewer and effluent pipe locations)

TANK TOP DIAGRAM (draw or attach diagram, note locations of risers)

IN-TANK FILTER(S) OR SCREENS? _____

EFFLUENT LINE LOCATION(S) _____

DRAINFIELD OR FINAL ABSORPTION SYSTEM

Size, lineal feet _____ Width of trench or bed _____

Gravel layer thickness _____ Depth to top of gravel _____

See also attached records or plans dated _____

Pressure distribution drainfield, see details located _____

Notes _____

Attach drawings or sketches. Include a copy of the original **as-built drawing of the system**. The installer is required to make a drawing of the system at the time it is installed. Get one from your installer or from the local health department.

AUXILIARY WATER DRAINAGE FEATURES, describe and/or note drawing locations.

Roof drains/downspout drains: Piped or directed to: _____

Footing drains: Drain or daylight to: _____

Curtain drains, or soil/groundwater interceptor drains (also called French drains):

Water collection drain location: _____ Directed or drained to: _____

Note: Curtain drains must be kept at a legal separation distance from drainfield. Contact designer or local health department for more information.

Driveway drain: Directed to: _____

Stairwell or entryway drains: Directed to: _____

Sump pump for basement or crawl space
(must not be connected to plumbing that leads to on-site system): Directed to: _____

PUMP CHAMBER(S) INFORMATION

Note: There may be more than one pump chamber, see design or system records

Location (in feet from reference points): _____

Design effluent dose volume and time: _____ Gallons _____ Minutes.

Pump chamber location diagram: (Attach sketch or other diagrams/drawings)

SOLIDS OR EFFLUENT PUMP(S) INFORMATION

Pump Brand: _____ Model: _____

Serial Number: _____ Purchased from: _____

Manufactured by: _____ Installed by: _____

Installation Date: _____

Manufacturers information, attach or specify location:

SOLIDS OR EFFLUENT PUMP REPAIR OR REPLACEMENT INFORMATION

Pump Brand: _____ Model: _____

Serial Number: _____ Purchased from: _____

Manufactured by: _____ Installed by: _____

Installation Date: _____

Manufacturers information, attach or specify location

ANY REPLACED SYSTEM COMPONENTS?

What? _____ When? _____ Why? _____

What? _____ When? _____ Why? _____

What? _____ When? _____ Why? _____

What? _____ When? _____ Why? _____

What? _____ When? _____ Why? _____

What? _____ When? _____ Why? _____

What? _____ When? _____ Why? _____

ELECTRICAL POWER AND PUMP CONTROLS LOCATION (DESCRIBE AND INCLUDE IN DIAGRAMS)

PUMP ELECTRICAL SERVICE PANEL LOCATION _____

Note: It is important to know where to shut off electricity prior to anybody working on pump or controls.

MONITORING AND MAINTENANCE RECORDS AND NOTES

WATER SUPPLY PLUMBING, LEAK CHECKS

Fixture/Appliance	Location	Observations	Actions
_____	_____	_____	_____
_____	_____	_____	_____
_____	_____	_____	_____
_____	_____	_____	_____
_____	_____	_____	_____
_____	_____	_____	_____

SEWER PLUMBING

Inside residence clean-outs located at: 1) _____ 2) _____
3) _____ 4) _____

Any rainwater or downspout drainage misdirected into sewer plumbing?

(If yes, must be corrected as soon as possible)

Clean-out between house and tank? Yes _____ No _____ If yes, located by _____

SEWER AND EFFLUENT LINES (PIPE ROUTING OUTSIDE OF RESIDENCE)

Sewer from house to tank inspected? _____ Notes: _____

Effluent line from tank to other components inspected? _____

Notes: _____

SEPTIC TANK MONITORING

Sludge and scum measured?

First chamber sludge _____ inches. Scum _____ inches.

Second chamber sludge _____ inches. Scum _____ inches.

Date _____ Pumped? _____ By: _____

Leaks into or from tank? _____ Repaired by _____

Condition of baffles _____

Effluent filters or screens cleaned _____

Notes: _____

Inspected by _____ See attached form dated _____

Health department inspection? _____ See attached form dated _____

SEPTIC TANK MONITORING

Sludge and scum measured?

First chamber sludge _____ inches. Scum _____ inches.

Second chamber sludge _____ inches. Scum _____ inches.

Date _____ Pumped? _____ By: _____

Leaks into or from tank? _____ Repaired by _____

Condition of baffles _____

Effluent filters or screens cleaned _____

Notes: _____

Inspected by _____ See attached form dated _____

Health department inspection? _____ See attached form dated _____

PUMP CHAMBER MONITORING

Leaks detected? _____ Into chamber? _____ From chamber? _____

Leaks at pipe entry? _____ Sludge removed? _____ Date _____

Sludge and scum layers measured? Sludge _____ inches Scum _____ inches

Notes: _____

PUMP CHAMBER MONITORING

Leaks detected? _____ Into chamber? _____ From chamber? _____

Leaks at pipe entry? _____ Sludge removed? _____ Date _____

Sludge and scum layers measured? Sludge _____ inches Scum _____ inches

Notes: _____

PUMP CONTROLS MONITORING

PUMP ELECTRICAL CONTROLS

Note: It is important to know where to shut off electricity prior to anybody working on pump or controls.

Outside control box located? _____

Circuit breakers at main electrical panel labeled? _____

Alarm tested? _____ Date _____

PUMP OR SIPHON MONITORING

If controls include a pump or siphon event counter and/or run-time meter, make a date and numbers recording log specifically for these readings.

Notes: _____

MONITORING PORTS MONITORING

Ports into system components (note water depth)

Port number _____ depth _____ inches. Date _____

Port number _____ depth _____ inches. Date _____

Port number _____ depth _____ inches. Date _____

Port number _____ depth _____ inches. Date _____

Port number _____ depth _____ inches. Date _____

Port number _____ depth _____ inches. Date _____

Port number _____ depth _____ inches. Date _____

OBSERVATIONS AT CLEAN-OUTS

Location _____ Comment _____

Location _____ Comment _____

Location _____ Comment _____

Location _____ Comment: _____

Location _____ Comment _____

Location _____ Comment _____

REPAIR AND REPLACEMENT NOTES

ON-SITE SYSTEM COMPONENTS

OPERATION, MONITORING, MAINTENANCE, AND OPTIONAL/IMPROVEMENT FEATURES

The following component sheets provide a brief explanation of each component found in your system. Each sheet is intended to have operation, monitoring, maintenance, and optional/improvement sections. The information provided is intended to be an aid to system owners. It is not intended to be an exhaustive technical manual for septic system professionals.

SOURCE WATER PLUMBING AND RESIDENTIAL WATER SUPPLY PLUMBING, WATER METERS

Operation: When a person turns on a faucet the pressure side of the plumbing delivers clean water to the point of use. Limiting use of water helps control water costs and helps the sewage system. A leak of only one-half cup per minute would deliver an unnecessary 45 gallons of water each day to your sewage system.

Monitoring: Sink and tub faucets and shower heads should not drip. Toilet flush valves should close completely when the tank is filled. There should be no leaks from the tank to the bowl after the tank is filled. To detect leakage from a toilet tank, place a few drops of food coloring in the tank reservoir and watch the toilet bowl for a few minutes. No color should appear in the toilet bowl until it is flushed.

Maintenance: Toilet flush valves, sink faucets, and all water shutoff valves should be repaired or replaced when ever leakage is detected.

OPTIONAL/IMPROVEMENT FEATURES

Flow restrictors. They can be installed in shower heads to reduce part of the waste water treated and disposed of by your septic system.

Pressure reduction valves. If water pressure is 60 psi or above, pressure reduction may help prevent water waste. Reducing pressure to 40 or 50 psi can help reduce the amount of water that escapes during faucet use. Fixtures still function when supplied with water at 40 or 50 psi.

Reduced flow at sink fixtures. Many sinks can have flow volume reduced by partly shutting off the fixture water supply valves under the sink. Experimentation can balance adequate flow for use, while reducing flow to limit waste water.

Low-flow toilets. Toilets with flushing volumes of less than 2 gallons per flush are now common and actually required for new construction. Low-flow toilets are available in plumbing supply and hardware stores. One- or two-liter soda bottles can be placed in existing high volume per flush toilet tanks. Toilets installed before July 1990 are probably higher volume flush toilets of up to 6 gallons per flush. Measure the flush volume using the following steps: 1. Turn off water supply valve to toilet. 2. Flush toilet to empty tank. 3. Refill tank with gallon jug until tank is filled to normal level. 4. Write down fill volume.

Low water use washing machines. Low water use machines are available where appliances are sold. Details of water volumes used are available from retailers or manufacturers.

Water meters. Being able to track daily, weekly, or monthly water use can help determine how much waste water is being generated. Of course, some of the incoming water may be diverted for irrigation, car washing, or other non-sewage production use. Meters are relatively inexpensive and easy to install. Water leak detection is also easier if a meter is present. Meter readings an hour apart, with all fixtures turned off, will show no meter change if there are no leaks or use within the system.

DRAIN PLUMBING, WASTE WATER (HOUSE SEWER LINES)

Drain plumbing is all of the pipes that carry waste water away from a fixture or appliance. This drain plumbing is usually connected to a main drain that exits the residence as a 3- or 4-inch sewer drain pipe.

Operation: In most residences, the waste water is collected into increasingly larger pipe sizes until it exits the building. It is important to retain building plans that show the location of sewer drain clean-outs.

Monitoring: Observe drain plumbing for leaks and repair as needed. Observe drain plumbing in the house crawl space or basement annually. With all faucets turned off and toilets checked to detect leakage, observe the main drain to detect any unexplained flow out of the residence and into the septic tank. Make observations at the septic tank inlet baffle or in the sewer pipe clean-out riser.

During the summer/dry season, observe the sewer and drain pipes. It is easier to detect leaks of water against dry soil.

Maintenance: Repair any leaking sewer pipe or pipe joints.

OPTIONAL/IMPROVEMENT FEATURES

Clean-outs. Clean-outs are pipe fittings that allow the inspection or cleaning of sewer or effluent pipes. They are mandatory at certain locations in house drain plumbing but are optional between the house and septic tank. Since the tank inlet baffle is a common location for blockage, the building to tank sewer pipe is an advisable location for a clean-out. Also a drain cleaning device can be introduced through a clean-out.

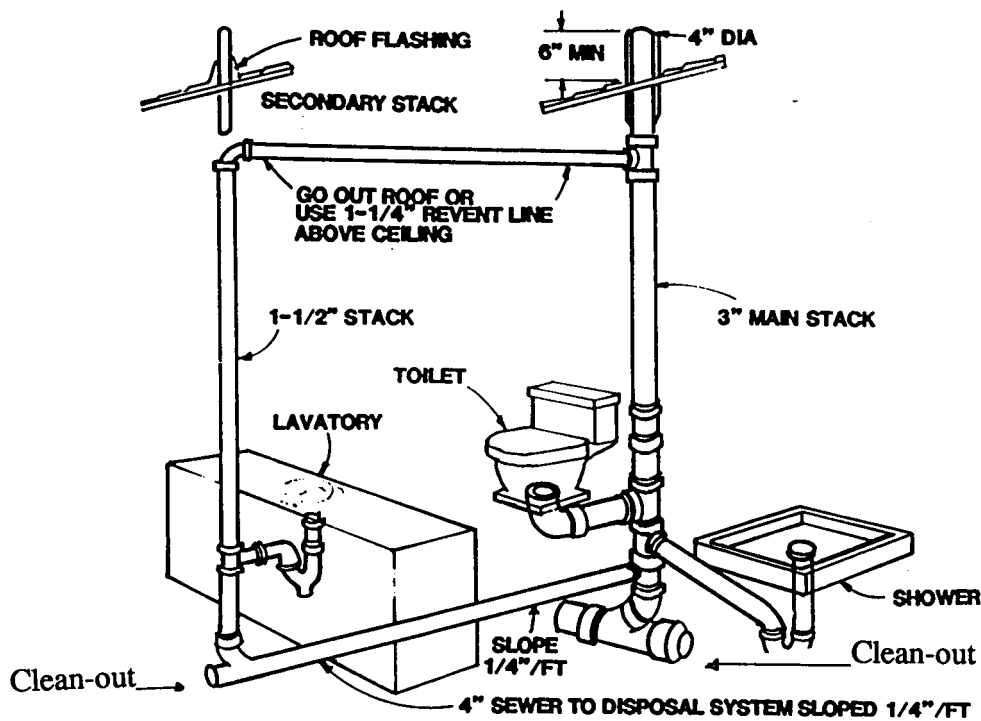

Household plumbing system.

SEWER LINE FROM RESIDENCE TO SEPTIC TANK OR FIRST COMPONENT

Operation: Sewer lines should be watertight. Discharge of excessive quantities of very hot water can cause pipe damage and can cause the resuspension of greases in the septic tank. When working or digging outside, be aware that sewer lines can be very close to the surface.

Monitoring: A sewer pipe should not let sewage out nor let ground water in. There should be no unusual wet spots near this pipe. Any pipe leakage point may become an entry point for roots to grow into the system, eventually causing pipe blockage.

Observe the pipe for any settling that might have occurred around the septic tank. The soil around the septic tank is difficult to compact when tanks are installed. If settling has occurred, the sewer line may be damaged and need to be replaced. Another way to detect pipe settling is during tank inspection.

Maintenance: Pipe breakage, cracks, leaks into or out of the pipe or at pipe joints must be repaired.

OPTIONAL/IMPROVEMENT FEATURES

Quality of pipe and joints. Depending on the year of installation, your sewer pipe may not be watertight. Examples of this are concrete or clay bell tile, and slip-joint plastic pipe installed by simply slipping a widened end over the adjacent length of pipe. If there is any indication of pipe leakage, it should be replaced with watertight pipe. Consult your building department or local health department for pipe standards.

Clean-out. There should be a clean-out for building plumbing at or near the location where the interior plumbing goes from vertical to horizontal. This clean-out as is may not be convenient for pipe cleaning or de-rooting the relatively flat sewer pipe under the house or from house to tank. A tee fitting with a cap can allow sewer cleaning devices to be introduced into the pipe and be run toward the tank or house.

SEPTIC TANK

A septic tank is a single or multi-chamber watertight vault or tank, designed to receive sewage and waste water from a residence or other sewage source. It is intended to retain solids and greases, allow microbial digestion of the retained materials, and allow the passage of the partially clarified sewage effluent to a following stage of treatment and disposal. Tanks are most commonly constructed of concrete, but can be made of other materials.

Baffles or tees are an essential part of the septic tank. These fittings, at the inlet and outlet of each chamber, are the primary devices that allow retention of solids and scum in each chamber of the tank. If they are damaged, fall off, or are not present for any reason, they must be replaced to restore tank function.

Operation: A septic tank must be watertight and not have holes or leaks that allow sewage effluent out of the tank, or ground water into the tank. Digestion that occurs in the tank is carried out by microorganisms that can live on very low levels of oxygen and without oxygen. Sewage flows into the tank, materials float or sink, and the clarified effluent passes to the second chamber in a two chamber tank, or to the next component if it is a one chamber tank. Tank baffles must be in place for proper operation.

Caution: *Do not enter an empty septic tank. It may contain toxic gasses or not have sufficient oxygen. Never leave the lids off without providing a barrier. Someone could fall into the open tank.*

Monitoring: Tanks are susceptible to cracking. Check for leakage where pipes enter or exit the tank and at the lids themselves. Leak detection should be an element of routine inspection. Watch for or ask the septic tank pumper to watch for black discoloration in the soil in contact with the tank lids. If present, this may indicate that there has been a high water level in the tank causing leakage from the top that is not normal. There should be no evidence of leakage into the tank before or after it is pumped, not through the walls, or at riser joints, pipe entry or exit joints. No effluent should run back into the tank from the drainfield or the pump chamber, if present. There should not be any flow into the tank from house plumbing when all fixtures are turned off.

The contents of your septic tank, the septage, can be removed on a fixed time schedule or be based on sludge and scum layer measurements. Scum should be no closer than 3 inches to the bottom of the outlet baffle, and sludge should be no closer than 12 inches to the bottom of the outlet baffle in standard tanks.

Sludge level measurement: The purpose of measuring sludge depth is to avoid allowing an accumulation that would allow the sludge to pass on to the drainfield. Measurement is made at or near the outlet of both chambers of a two-chamber septic tank. First measure total tank depth and the depth of the outlet baffles in each chamber. Measure sludge and scum as close to the outlet baffles as possible. Do not measure sludge depth or scum layer thickness at or near the chamber inlet baffles.

There are several commercial devices to measure sludge depth. One is a clear tube with a valve at the lower end of the tube. The tube is inserted into the tank and a cross section of tank materials go into the tube. The foot valve is closed and the tube is taken from the tank. Measurements are taken from direct observation of tube contents and then the contents are returned to the tank. Another device uses light transmittance to determine the tank liquid clarity or sludge density.

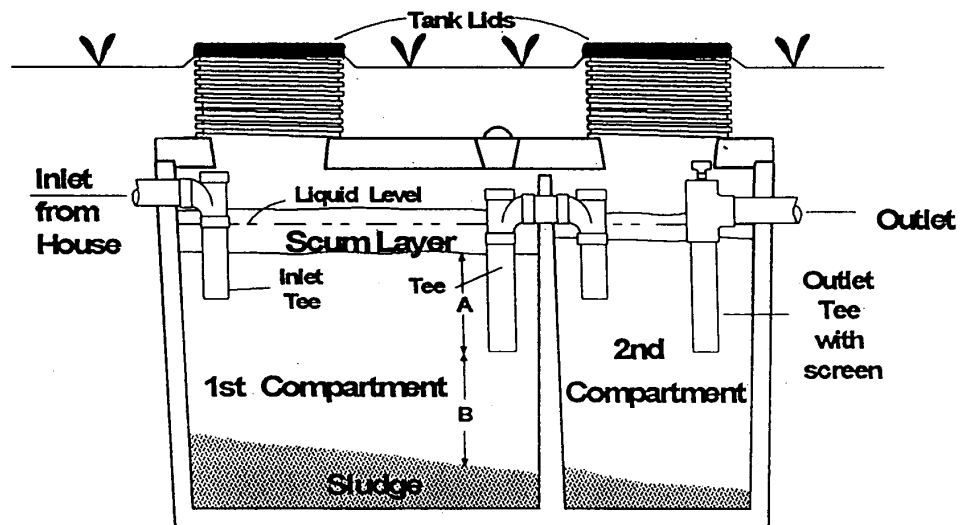
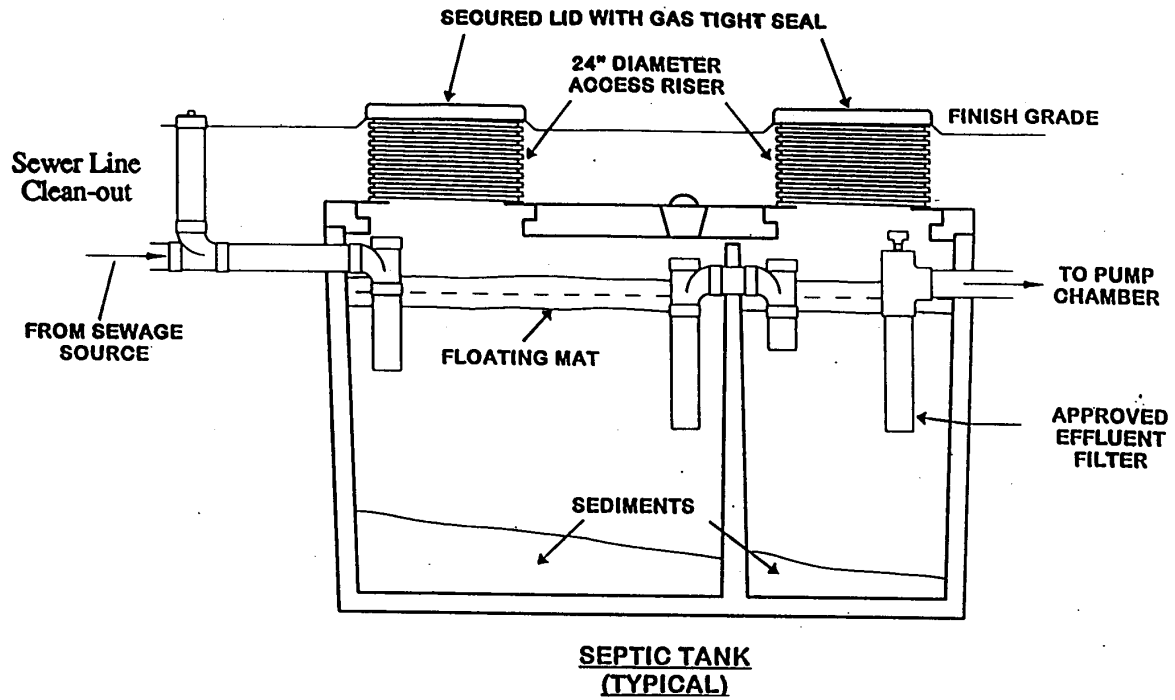

**Pump Tank Out When:
"A" is 3 inches or less, or
"B" is 12 inches or less**

A simple method is to wrap 3 or more feet of light colored toweling around a 6 foot or longer stick. Push the wrapped stick down into the tank, hold in place for 1 to 2 minutes to allow black sludge to adhere to the cloth, and slowly pull it out. Sludge will show as a black coating on the cloth. Record the sludge layer thickness. When finished, place the cloth into a plastic bag, seal and discard in the garbage.

Scum measurement: Scum is measured by using a pole with a flat surface attached to its end. Carefully place the device through the scum blanket. Pull the device toward the under surface of the floating material. Measure and note the thickness by using a reference point on the pole. Note distance from bottom of scum layer to bottom of chamber outlet baffle or tee. Wash material on the measurement pole back into tank when finished.

Maintenance: Maintenance is primarily removal of the entire tank contents, the septage, the settled solids and the floating materials or scum layer. Septage should be removed before the sludge accumulation (from the bottom up) or the scum layer (from the top down) reaches the middle, clarified layer, and can be passed onto the next chamber or component. When the tank is monitored or inspected, both chambers should be examined. Whenever sludge or scum accumulations indicate the need for tank pumping, all chambers should be pumped, including any separate pump chamber or d-box.

OPTIONAL/IMPROVEMENT FEATURES

Risers. Tank risers are tubes made of metal, concrete, or plastic, fixed to the tank top over the various tank lids to allow inspection, baffle cleaning, and septage removal. Risers allow access to tanks without the repeated digging of soil cover. Making the joint between riser and tank watertight to prevent ground water entry is important in locations where water table level exceeds tank top elevation. Risers are a time and effort saver for periodic monitoring and maintenance.

Locating devices. Devices used to locate system components can be as simple as the establishment of reference points with measurements and written notes and diagrams. They can also include the installation of toning metal or wire for electronic instrument detection.

**Devices for Measuring
Sludge and Scum in the
Septic Tank**
(Adapted from PHS
Publication No. 526)

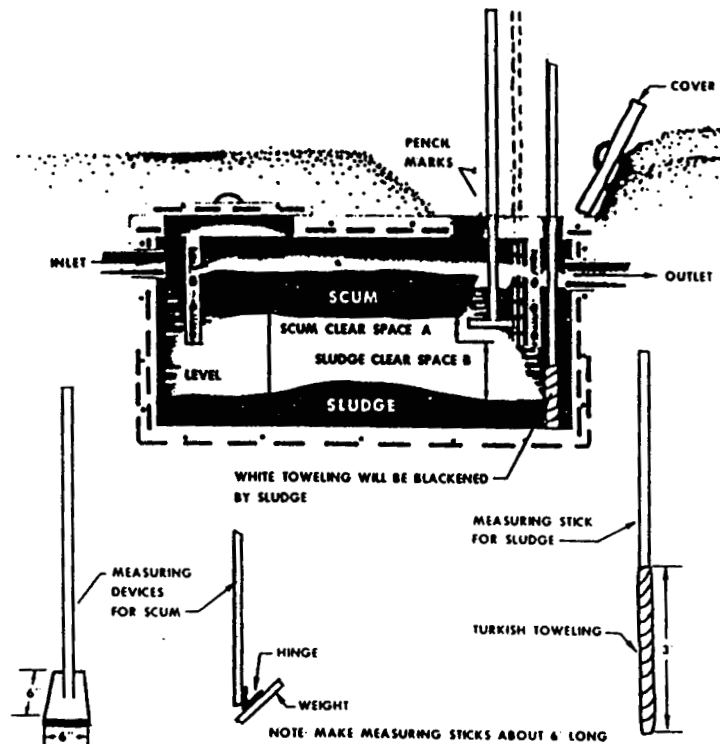

ACCESS HATCHES AND RISERS TO TANKS

Risers are tubes made of metal, concrete, or plastic, approximately 24 inches in diameter, fixed to the septic tank top or over the various tank lids to allow inspection, baffle cleaning, and septage removal. Risers allow access to tanks without the repeated digging of soil cover. Risers are a time and effort saver for periodic monitoring and maintenance.

Operation: Risers do not require special operation techniques. The lids that are attached to the riser top must be protected from vehicle traffic. Lids must be securely attached to prevent accidents or vandalism.

Monitoring: During routine examination of the system, components, and system structures, examine all joint or connection seals to assure that leaking into or out of the system does not occur.

Maintenance: Repair any leakage or mechanical damage found during inspection of the on-site system.

Optional/Improvement Features: None known.

IN-TANK FILTERS AND SCREENS

Effluent filters are devices usually inserted or built into the second tank chamber vertical outlet baffle to increase solids settling and further limit solids carry-over into the next component. Effluent filters have been considered optional but are required on some new systems.

Operation: Filters and screens operate by producing still-water zones. These still-water zones allow near neutral buoyancy materials to settle and not be carried toward the drainfield.

Monitoring: Filters and screens should be examined to detect clogging or accumulation of solids. If your filter or screen is causing sewage to back up into your house, you need to look at your water usage and other household waste disposal practices to determine the problem.

Maintenance: Filters and screens should be cleaned by rinsing solids back into the tank during septic tank pumping.

OPTIONAL/IMPROVEMENT FEATURES

Effluent filters. Easily installed into existing septic tank outlet baffles, effluent filters should improve your septic system's performance.

EFFLUENT PIPES BETWEEN SEPTIC TANK(S) AND OTHER COMPONENTS

Operation: The pipe between the septic tank and the next component is designed to be watertight. In gravity drainfields, this pipe is usually plastic and short, a 3 to 10 foot length of 4-inch pipe. The pipe should be properly sealed at the septic tank outlet; there should be no sagging or pipe deformity due to settling around the tank.

Pipe joints that enter and exit tanks and pump chambers should have flexible connections or flexible couplers. Rigid joints between tanks and pipes are the most likely to leak.

Effluent lines between pump chambers and downstream components should also be completely watertight. The effluent pipe is frequently in the size range of 1 to 2 inches in diameter. The pipe size should be shown on design or “as-built” documents.

Monitoring: Know the location and route of all sewage transport lines. Initial installation should have separately located any sewage effluent lines away from drinking water supply lines. Both locations need to be known. Perform dry season monitoring of effluent line locations to detect any leaks. Wet or unusual green plant growth areas may signal a pipe break or joint leak.

Pipe is commonly protected at initial installation by an additional pipe as a casing at road or driveway crossings. A permit is required to construct a pipe crossing of a county road or state highway. For requirements regarding state road or highway crossings, call the Washington State Department of Transportation, Regional Utilities Engineer at the regional office. See the government pages in your phone directory under Washington, State of, Transportation Department. For county road crossing information, call your county department of public works.

Maintenance: Any leaks should be repaired immediately by qualified personnel.

If pipe sagging or deformity is detected the pipe should be replaced.

OPTIONAL/IMPROVEMENT FEATURES

Location markers. Locate and clearly mark the location of all effluent pipe routes on and off the property. Use locator tape or wire if a pipe is being replaced and a trench is open. Another method is to place marker stakes in known locations and make careful measurements for mapping the locations of pipes, cleanouts, and valves.

Road markers. A sign at the edge of your property, not on the road right of way, should be posted and maintained to reduce the possibility of pipe damage by road maintenance equipment or utility companies, as a reminder of pipe location.

Pipe protection. Protect any pipe location that may be subject to vehicle traffic. Consult the local health department or a certified installer for specific methods of pipe protection.

CLEAN-OUTS

Operation: Clean-outs are fittings installed into or at the ends of pipes to allow the removal of accumulated solids or clogging materials. Clean-outs can decrease maintenance costs during times of emergency or component failure.

Monitoring: Through clean-outs and monitoring ports you can usually observe the presence or absence of sewage or effluent. If effluent was present in a drainfield monitoring port, the depth of the water would be an item to note. Interpretation of the observation may require reference to the system design and operation and maintenance manual or consultation with the local health department or other on-site professional.

Maintenance: Clean-outs allow maintenance through them. Clean-outs constructed as part of a pressure distribution drainfield or a mound system drainfield are present to allow the cleaning of the very small effluent holes in the distribution pipe.

Caution: A sewer blockage at the septic tank inlet baffle could cause sewage to escape at the clean-out if there has been a backup into the residence. Sewer clogging at the inlet baffle of the septic tank is one of the most common blockage locations. This is a good reason to have a riser above the inlet baffle to the septic tank.

OPTIONAL/IMPROVEMENT FEATURES

Clean-outs. They are more convenient to install when a tank or trench is open for other work, but can be installed as a specific improvement project. Any time repair work is done to an on-site system component it is wise to consider the addition of clean-outs and/or observation ports. Like tank risers, they can decrease the cost of monitoring and maintenance.

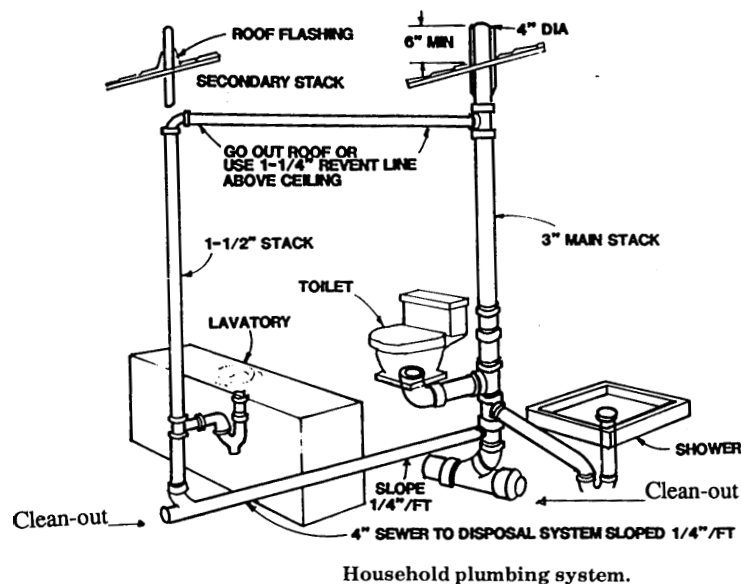
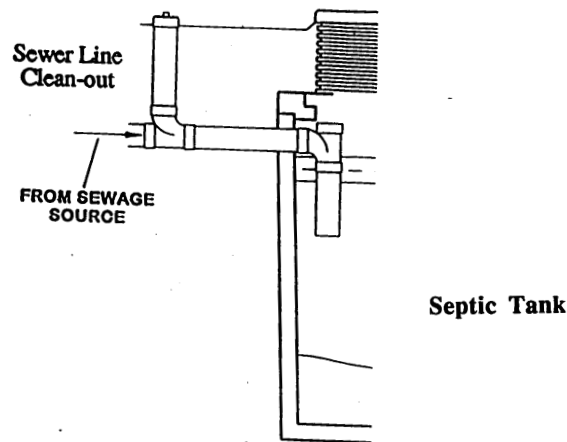

DISTRIBUTION BOX (D-BOX)

Operation: A distribution box is usually a concrete structure intended to distribute effluent evenly to two or more drainfield effluent trenches. One inlet port from the septic tank is followed by two or more outlet ports at a lower elevation. Research has shown that this type of distribution method is not very effective because of the very small elevation differences in outlet ports.

Monitoring: To monitor a D-box it must be uncovered and the lid removed. Observe water flowing into the box and the distribution of effluent to the outlet ports. Close examination of the outlet ports may detect uneven discharge from the box.

Maintenance: Re-leveling or installing flow equalizers may help.

OPTIONAL/IMPROVEMENT FEATURES

D-box effluent distribution levelers. Levelers can be installed in the outlet ports. They are usually plastic inserts and are intended to allow the adjustment of effluent quantity between drainfield lines to achieve better balance of effluent distribution or to rest a leg of the field. Actual equal distribution is probably not possible in a gravity drainfield.

Location marker. A locator wire or iron re-bar can be installed when the trench or D-box is open. A riser can be installed at or above the D-box depending on the site.

Distribution Box

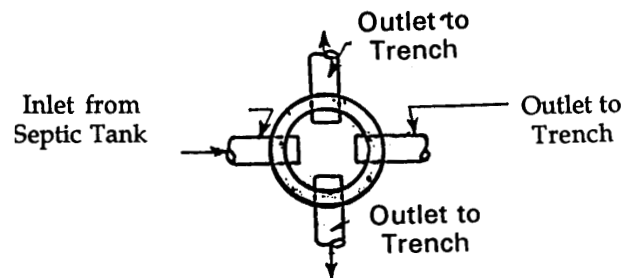

GRAVITY DISTRIBUTION DRAINFIELD

Gravity distribution drainfields are trenches and beds that distribute septic tank effluent by gravity flow. They usually receive effluent by gravity but can receive effluent from a siphon or pump. In simple gravity flow, when a volume of waste water is discharged to the septic tank, this volume is displaced and flows toward the drainfield. A common trench cross section is 2 to 3 feet wide with 6 inches of washed drainfield rock below the 4-inch perforated pipe, and 2 inches of rock cover above the pipe. This yields 12 inches of washed rock. Native soil cover could range from 6 inches to 24 inches depending on the system design.

Operation: The drainfield is in operation and receives septic tank effluent every time household drain plumbing is used. Higher quality effluent from the septic tank allows a longer drainfield life without clogging at the drain rock/soil interface. Clogging, when it does occur, is usually within the first 4 inches of native soil. Gravity drainfields do not usually distribute effluent evenly throughout the drainfield. This uneven flow can allow deep penetration of partially treated effluent if adverse geological conditions exist. Prevention of excess effluent quantity, and excess solids and greases from entering the field are operation goals. Water use control, limiting grease discharge, and periodic solids removal are the primary preventatives.

Monitoring: Periodic examination of the drainfield area is necessary to note any areas of soft or wet soil, areas or lines of green grass surrounded by dryer grass. Note any locations of water seepage below or downhill from the drainfield location. Seepage can be an indication of drainfield failure and can cause dangerous health hazards.

Observe any locations of soil or earth subsidence (sinking or depression) over drainfield trench locations. This can indicate that soil above the drainfield gravel is settling into the spaces between the drain rock. This can indicate severe drainfield ponding and imminent drainfield failure.

Maintenance: Most gravity drainfields have not been constructed for actual field maintenance. Distribution boxes can be inspected and leveled to assure more even distribution of effluent.

OPTIONAL/IMPROVEMENT FEATURES

Monitoring ports. Ports can be constructed into the drainfield. They allow the direct observation of effluent level in the drainfield. These can be important early warning devices to detect field clogging. Monitoring ports can also be placed near the drainfield, 2 to 4 feet deeper than the bottom of the drainfield gravel. This allows for the observation of water table elevation that may effect drainfield function.

Effluent filters. Filters can be added at the outlet baffle of a septic tank to decrease solids carry-over to the next component.

Landscaping. It is important and beneficial to your drainfield to landscape it with shallow rooted plants. These plants will help to take up nutrients and water in the drainfield. For more information see "Landscaping Your Septic System" by Washington Sea Grant, publication No. WSG-AS 98-02. Call 360-543-6600 for copies.

Surface water control. Divert all surface and rooftop water runoff away from the drainfield area. Do not construct any kind of trench or drain near a drainfield unless there is a clear understanding of the potential impact on the drainfield or from the drainfield.

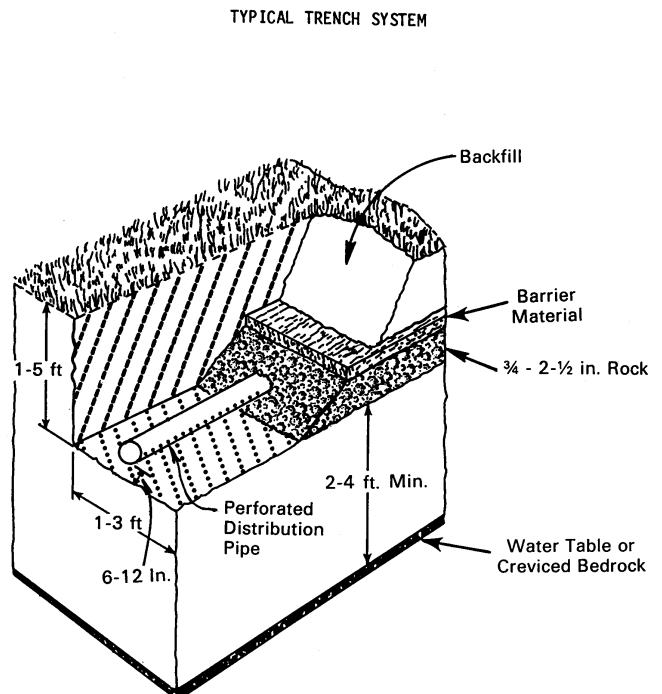

MONITORING PORTS

Operation: Monitoring ports are tubes or pipes that allow examination of the internal working of system components and sewage effluent or water levels. Usually they are perforated pipes surrounded by gravel, cut off at ground surface or above ground if protected from damage. They are capped to prevent filling that destroys the basic function of the port.

In a mound drainfield system or constructed sand filter, monitoring ports are installed at two depths; first, to the base of the drainfield rock in the effluent distribution system above the sand layer(s), to identify effluent ponding or excess use, and second, to the native soil/fill soil interface.

Where monitoring ports are installed to or into native soil for determining the elevation of standing water, care should be exercised to avoid penetration or damage to the actual drainfield gravel/soil or fill interface.

Monitoring: The liquid level in the port is usually the most important information to obtain. Interpretation of this observation rests on the intended function of the component. Some temporary ponding in the drainfield gravel after pump discharge is normal. Short-term or temporary ponding in a gravity distribution drainfield can also be normal. Persistent ponding in the drainfield gravel can indicate excess sewage discharge, drainage water saturating the drainfield area, or gradual clogging of the soil around the drainfield gravel.

Maintenance: It is important to protect monitoring ports from mechanical damage by machinery or vehicles. Do not fill with gravel or other material, this blocks the ability to observe and measure water levels.

OPTIONAL/IMPROVEMENT FEATURES

Monitoring ports. Installation can be done at times of opportunity or as a retrofitting project. Specification can be obtained from the environmental health department or a system designer. Monitoring ports can also be installed into native soil near drainfields to observe soil saturation of hardpan or clay layers.

Gravity Distribution Drainfield Cross Section with Monitoring Port

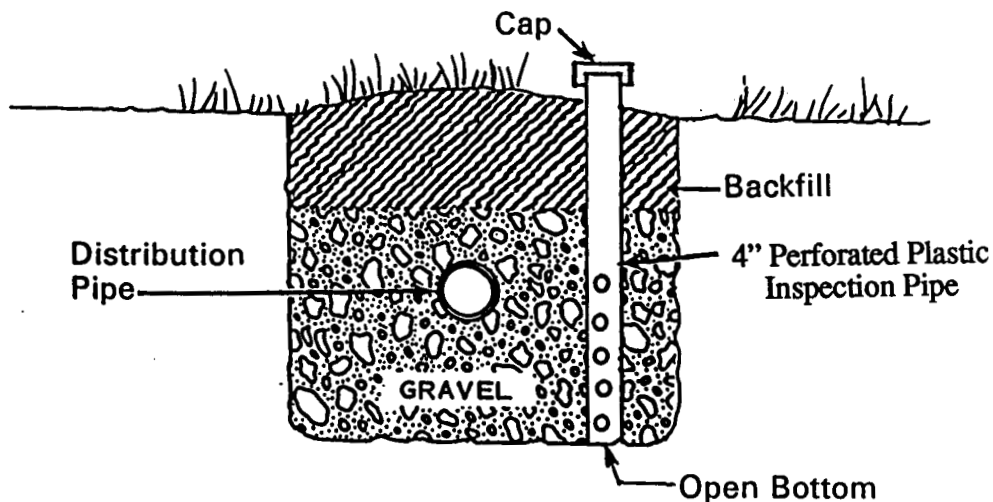

SEEPAGE PIT

Operation: A seepage pit or dry well is an older style sewage effluent disposal system, no longer commonly used. This system was used on small lots or in areas where the surface soil was less permeable than deeper layers. Effluent disposal was the goal of this system type and little thought was given to treatment effectiveness or aquifer contamination.

Monitoring: Seepage pits are monitored by direct observation through a removable lid similar to a septic tank lid placed in a precast concrete seepage pit lid. Well water sampling for both fecal coliform bacteria and nitrate should be a component of your seepage pit monitoring.

Maintenance: Sludge accumulated in the pit should be removed. Protecting the pit from physical damage is necessary. During the decades of occasional use, there were no adopted pit top strength standards in place. Top strength was determined by the installing contractor.

OPTIONAL/IMPROVEMENT FEATURES

Little can be done to increase treatment effectiveness of a seepage pit. If space is available, replace it with an effective treatment system. If a pit is abandoned and another system used, removal or filling of the pit is highly advisable.

Risers. They can be added to allow easier access and observation.

Location marking. It is important to prevent top breakage or collapse.

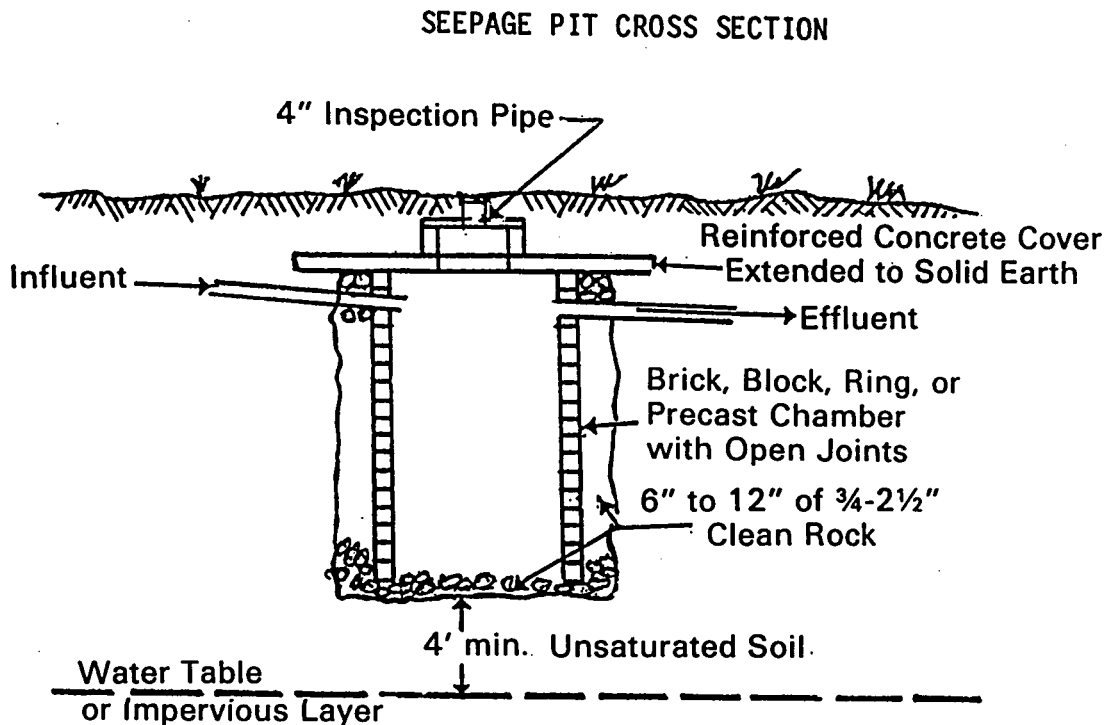

PUMP CHAMBER

Operation: Pump chambers are watertight tanks, designed to operate automatically with the pump controls. Effluent flows into the pump chamber by gravity when a batch of water is drained into the septic tank. Two gallons of waste water into the septic tank would displace 2 gallons of effluent from the tank, that would then flow to the pump chamber. As the effluent level in the chamber rises, a float switch is activated that activates the pump. The pump delivers effluent to the next component in the system.

A common arrangement of float switches is: the on and off switch, a redundant or backup off switch, and a high level alarm switch. Though not designed to settle solids, some sludge will accumulate in the chamber bottom. Timers are common pump controllers on newer systems.

Monitoring: Monitoring is by direct chamber observation and correlation with use of system and pump controls. Note effluent level in chamber and record your observations. Note any leaks into or out of the chamber, especially at pipe entry and exit, and repair if detected. Observe the amounts of scum and sludge in the pump chamber.

Maintenance: Manually exercise the float switches, look for float switch tangling or hanging up that would interfere with normal function. Have sludge removed when the septic tank is pumped. Clean any screens or in-line filters.

OPTIONAL/IMPROVEMENT FEATURES

Risers. A riser can be installed to allow easier pump chamber and pump observation. Risers are highly advisable as they can significantly reduce labor at times of pump or float control problems. Risers have been required for many systems since July 1996. Risers must be able to be secured and made watertight.

Effluent filters. Filters can be installed before the pump chamber in the septic tank outlet baffle. Another type of filter can be installed downstream from the pump to reduce particulate material delivered to the drainfield.

Larger pump chamber size. This can be of value if the existing pump chamber does not have reserve storage capacity. Older pump chambers have commonly been 1 to 300 gallons; newer systems frequently use single-chamber septic tanks with controls suitable for this larger size.

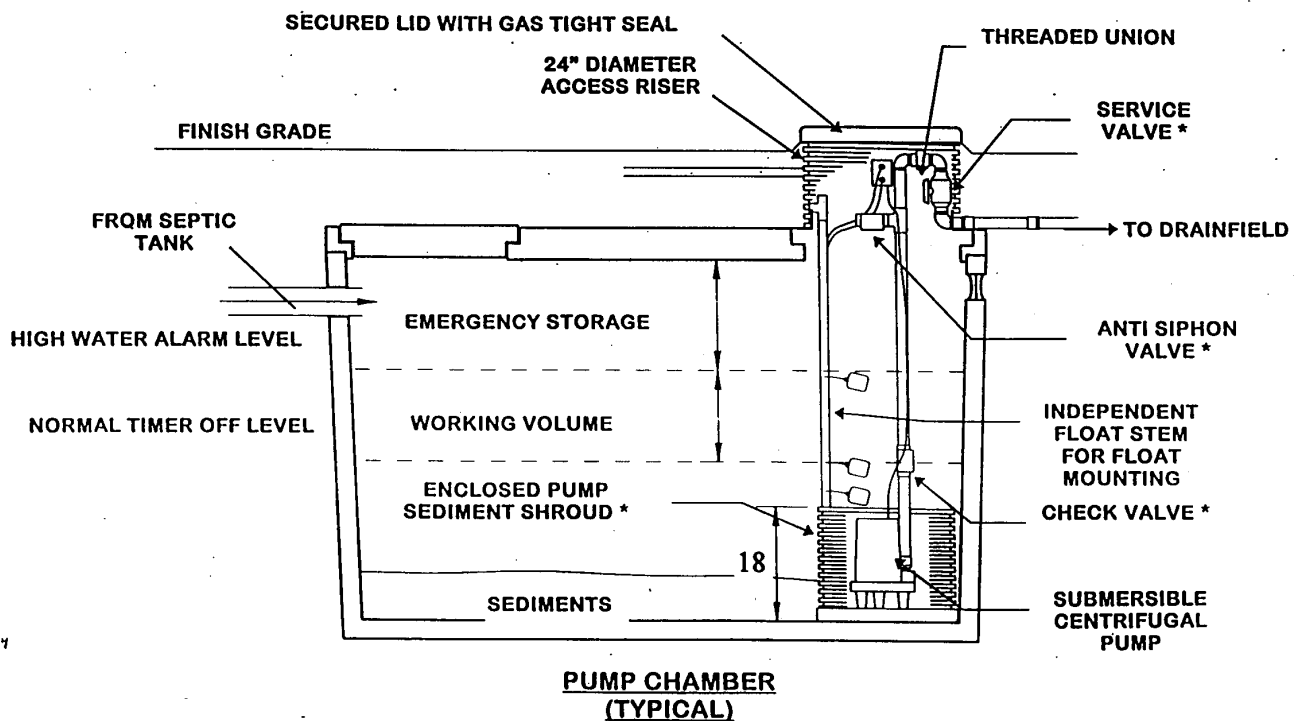

* AS NEEDED

SOLIDS PUMP

Solids or ejector pumps are not common in on-site systems. Sometimes also designed and called grinder pumps, they are used to deliver raw sewage to a septic tank. They can be used when adding a bathroom to a basement where elevation is below the flow line or elevation of the on-site system.

Operation: Solids or ejector pumps usually have a very small pump chamber located very close to a single served fixture or bathroom. Occasionally an ejector pump is used to allow installation of the tank and drainfield in an area that is more feasible for installation equipment to reach.

Monitoring: Check the vault for leaks and monitor the pump for proper function.

Maintenance: Fix any leaks detected immediately. Maintenance is specific to the make and model owned. Check your pump's operation and maintenance manual for detailed information.

OPTIONAL/IMPROVEMENT FEATURES

None known.

EFFLUENT PUMP

Operation: Effluent pumps are designed to deliver treated or partially treated sewage effluent to a drainfield or other system component. They are now commonly designed to be submersible and to function completely under water. Pumps can be single stage low pressure or multi-staged higher pressure, and can thus lift effluent to locations hundreds of feet above the pump location.

Monitoring: Pumps can usually be heard when activated; learn what the pump cycle sounds like. Learn which electrical panel circuit breaker or breakers control the pump and controls and make sure they are clearly marked at the panel. Know where the pump controls are located outside the residence. You should know how to reset the circuit breakers and how to shut off the alarm and pump circuits during an emergency. Observe float-switches to make sure they are functioning properly.

Monitor the pump operation cycle during high rainfall periods and when the area at or around the septic tank and pump chamber appears to be at its wettest. If the pump cycle is more frequent during these periods, leakage into the system is a possibility. Leaks into the system must be repaired as soon as possible.

Maintenance: Remove settled sludge in the pump chamber when the septic tank is pumped. Make sure that rocks of any size stay out of the pump chamber. Effluent pumps are not designed to receive and pass rocks through them.

OPTIONAL/IMPROVEMENT FEATURES

Though the following subcomponents are frequently constructed into a system when initially installed, they may be added to solve certain operation problems and to build valuable diagnostic information.

Event counters. Installed at the control panel, an event counter records the number of times the pump has discharged sewage effluent to the next component or drainfield. By itself it gives only a rough estimate of effluent volume discharged in a time period. It is an excellent way of building a record of effluent generated and delivered to a treatment unit or drainfield that also provides treatment.

Run-time meters. To record the total elapsed time the pump operates, install a run-time meter. This is an excellent way to check pump chamber and pump operation, and to help determine whether there are leaks into the system.

Timers. Control pump on-time as well as off-time by installing a timer. Timers can help even out effluent volumes delivered to a drainfield over a specific time period and guarantee a rest period between doses. Timers can also restrict the maximum effluent dosed to the system to the maximum daily design loading. Timers are also used with surge tanks that are installed to manage uneven daily volumes.

ELECTRICAL POWER CONTROLS

Caution: *Electrical Power is Dangerous! Avoid Electrical Shock Hazards! Take great care when inspecting or working with electrical equipment. Follow electrical code standards, employ qualified personnel and have work inspected by the electrical inspection division of the building department or the Washington State Department of Labor and Industries, Electrical Division when necessary.*

Operation: Know which electrical panel circuits and circuit breakers control the pump, controls, and high level alarms. Make sure that they are marked at the panel for easy shutoff and for resetting if a circuit breaker is tripped. An outside electrical control box, usually located in sight of the pump chamber itself, will usually contain pump controls and a major electricity shut-off switch. The off switch or switch box should be lockable to prevent electricity turn-on while any pump chamber circuitry is being worked on. If an alarm sounds or an alarm light appears, make sure the problem is diagnosed and repaired as soon as possible.

Monitoring: Check the outside electrical box to determine if water is entering this watertight box. Watch for evidence of corrosion.

Maintenance: Have corroded or damaged parts replaced by qualified personnel.

OPTIONAL/IMPROVEMENT FEATURES

If there is any doubt as to whether the electrical controls are up to code, call a sewage system installer or electrician for advice.

PUMP CONTROLS, ALARMS

Caution: *Work on controls should be performed only by qualified persons.*

Operation: Pump cycle controls are designed, manufactured, and installed to accomplish specific system design functions. Float switches are usually attached to a vertical rod or piece of pipe that does not carry effluent, called a "float tree." Pump control complexity can vary. A basic float-switch assembly could be composed of a primary on/off float switch and a high level alarm switch. To the basic assembly, a redundant "off" switch can be added to assure that the pump is turned off in the event of primary on/off switch or control panel problems. Separate float switches can be located and wired to accomplish larger doses or more complex pump functions. For proper treatment to occur in drainfields, mound systems, and sand filters, proper design and settings of controls are essential. Deviation from design specifications may cause treatment or hydraulic failure of the sewage system. Controls should be installed in a dry location or be designed to tolerate a moist environment.

Monitoring: Learn from design documents the specifics of pump cycling or other features. Take the data from any event counter or pump run-time meters for recording periodically in your monitoring and maintenance records. If a high level alarm sounds, or warning light goes on, the effluent level is probably high. There may be several causes. Among these can be excess water volume entry into the system, pump, pump control, or float switch control problems.

A tripped circuit breaker may indicate an electrical problem but could have also been tripped by sudden line voltage change. If a circuit breaker is tripped, turn it all the way "off," and reset it to the "on" position. Observe pump or control function. If the circuit breaker trips again immediately, call your system installer. Consult the system design manual for more specific troubleshooting instructions and call your installer or certified maintenance personnel.

If an alarm sounds or an alarm light appears, make sure the problem is diagnosed and repaired as soon as possible. The alarm is there to inform the owner of malfunction and protect the sewage system from damage.

Maintenance: Controls should be examined periodically to assure there has not been any corrosion or any unplanned water entry. Call a licensed installer or contractor to discuss your findings.

OPTIONAL/IMPROVEMENT FEATURES

Event counters. Installed at the control panel, an event counter records the number of times the pump has discharged sewage effluent to the next component or drainfield. By itself it gives only a rough estimate of effluent volume discharged in a time period. It is an excellent way of building a record of effluent generated and delivered to a treatment unit or drainfield that also provides treatment.

Run-time meters. Installed to record the total elapsed time the pump operates, run-time meters are an excellent way to check pump chamber and pump operation and to help determine whether there are leaks into the system.

Timers. Control pump on-time as well as off-time by installing a timer. Timers can help even out the effluent volume that is delivered to a drainfield over a specific time period.

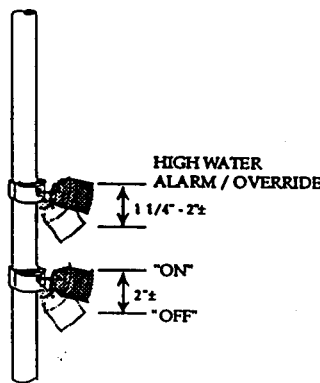

Basic Float Assembly

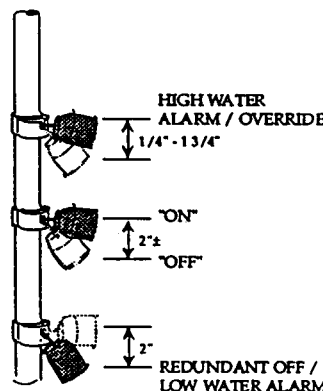

Basic Float Assembly With Redundant Off

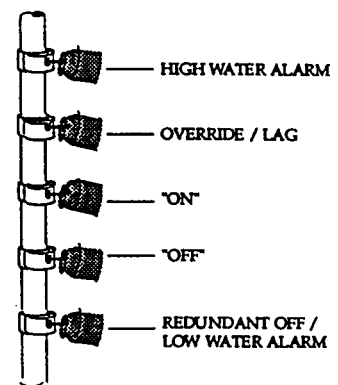

Separate Float Functions For Large Doses

Level Control Foat Assemblies

Terry R. Bounds, P.E.*

DOSING SIPHON

Operation: A dosing siphon is housed in a siphon tank and is used to deliver a specific quantity of sewage effluent to a drainfield or treatment device. It is designed to discharge automatically when the level of effluent reaches a certain depth. The siphon is intended to deliver a uniform volume of effluent per cycle. Siphons usually discharge at a fairly high discharge rate. High discharge volume reduces the discharge time and thus reduces the variability that can be caused by additional effluent reaching the siphon tank during the discharge cycle.

Monitoring: Periodically observe the dosing tank and siphon. Observe the discharge cycle. Watch for bubbles when siphon parts are covered with water. Make sure that the siphon tank fills and then empties when the siphon discharges.

Maintenance: Professional maintenance is required if your siphon malfunctions. Check your siphon component guidelines with your system file for specific information.

OPTIONAL/IMPROVEMENT FEATURES

Risers. A riser can be installed to allow pump chamber and siphon observation without excavation, (looking without digging). Risers are highly advisable as they can significantly reduce labor at times of siphon failure and repair. Risers have been required for many systems since July 1996. Risers must be able to be secured and made watertight.

Event counters. An event counter records the number of times the siphon has discharged sewage effluent to the next component or drainfield. By recording the number of discharge cycles, it gives an estimate of effluent volume discharged in a time period. It is an excellent way of building a record of effluent generated and delivered to a treatment unit or drainfield that also provides treatment.

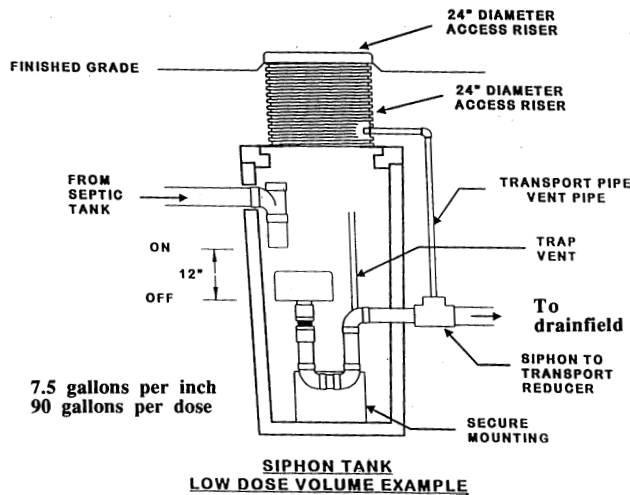
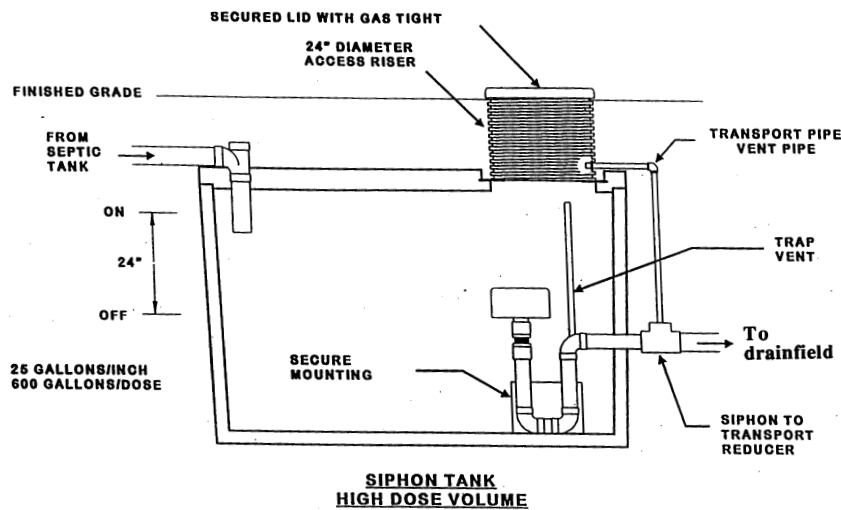

CURTAIN DRAINS

These drains are constructed of washed gravel and perforated drainage pipe to intercept shallow ground water, usually less than 60 inches deep. They are most effective when there are abrupt soil texture changes, such as sandy material lying over nearly impermeable hardpan (glacial till) or a clay layer. Their function depends on adequate slope and adequate separation distance from such a drain to any potential contamination source.

Operation: These drains are usually constructed to function via gravity flow of water through soil layers into the washed rock and drainage pipe. Flow is then directed to a location that will not do harm to any sewage systems or neighboring property.

Monitoring: Examine the discharge pipe during winter wet weather to determine whether the drain is actually collecting and transporting water. Examine any monitoring ports into or near the drainfield to detect whether the drainfield and the drainfield area have excess water during wet periods. These inspections should be done during both wet and dry periods to establish comparisons.

Maintenance: Protect the land surface over the interceptor drain location to prevent siltation and clogging of the drain rock and drain pipe. Protect the pipe discharge location to prevent pipe crushing or clogging.

OPTIONAL/IMPROVEMENT FEATURES

None known.

ON-SITE SYSTEM OPERATION

THE WATER USE CYCLE

Every on-site sewage treatment and disposal system begins operation with people using fixtures and appliances, and ends with treated waste and waste water re-entering the environment.

System components transport, treat, and dispose of waste and waste water that is generated in the residence. No system is likely to have all of the items listed in the component checklist, but will usually have several of them.

TREATMENT GOALS

Waste water is successfully treated when contaminants are removed to the degree that illness is not transmitted and surface water and ground water are not polluted. It is the nature of on-site sewage treatment and disposal systems to have both water flow and treatment capacity limits. Reduction in wastewater volume and the quantity of materials that need treatment usually helps reduce the chances of system failure or water pollution.

WATER CONSERVATION

Approximately 75% of waste water is generated by toilet use, laundry, and bathing. Reduction in flow volumes in these three categories can yield the greatest results in wastewater volume control.

RECREATIONAL VEHICLE SEWAGE TANK DUMP FACILITIES CAUTION

Sewer lines to on-site systems for the purpose of receiving sewage waste from recreational vehicles (RV's) have occasionally been added to on-site systems. This is not advisable unless such a sewer line has been planned for and the on-site system tank(s) and drainfield have been enlarged to handle the additional waste loading. Only if the entire system has been designed for the additional waste may the system be used for this purpose. If it has been so designed, use great care to allow only the approved waste quantity at the approved frequency to avoid overloading and possible system failure.

RV storage tank waste can have many times the waste strength of ordinary household sewage because it lacks the dilution of sewage carrying water. Some tanks are also treated with preservatives that are not advisable for septic tanks.

If the on-site system has not been designed to handle RV tank waste, do not use or allow the use of the system for this purpose. The elevated waste strength can have significant negative impact on drainfields. Excess waste strength can pass through septic tanks and cause biological clogging in the soil around the drainfield gravel.

EMERGENCY OPERATION DUE TO EXCESSIVE WATER IN DRAINFIELD AREA

Operation: On-site system owners should be aware of how high-intensity rainfall affects their on-site system. Excess water can be a problem in any type of system. (See Emergency Operation Due to Power Outages).

Bacteria and viruses are most effectively removed when effluent passes slowly through unsaturated soil. Saturation of the soils in the drainfield area may allow rapid movement of bacteria and viruses. The rate of lateral, downhill movement may change from a few feet per day to over 10 feet per hour. This can in turn allow the discharge of bacteria and viruses into nearby surface waters. This would generally not be detectable without taking water samples and testing them in the laboratory. If a drainfield area, or location downhill from a drainfield seeps or runs water after storm events, contact an installer or the health department for further analysis and information.

Monitoring: The primary observations are into monitoring ports in the drainfield itself and into monitoring ports near the field into native soil, 1 to 2 feet below the elevation of the bottom of the drainfield gravel. Make two kinds of observations. First, make a series of background observations to learn about your system in all of the seasons. Observations can be made monthly or before, during, and after rainstorms. Second, make occasional, or scheduled observations and record the water depth if standing water does show in the ports. Call an installer, designer, or the health department for help in interpreting changes in observed water levels.

Maintenance: Periodically check and clear drains and catch basins to prevent misdirected water flow. Examine any interceptor drains that may have been constructed to protect a drainfield from surface water. Protect observation ports from mechanical damage.

OPTIONAL/IMPROVEMENT FEATURES

The following recommendations are intended to help sewage systems function more effectively but are not a guarantee of adequate system performance. The recommendations may help reduce the quantity of contaminants reaching streams, lakes, or marine waters.

1. Develop a plan in advance of the rainy season, and make observations during the wet season.
2. Install or have installed monitoring ports into the soil, near the drainfield in addition to any into the drainfield. (See monitoring ports section for details).
3. Monitor the water depth in the monitoring ports and note whether the standing water depth recedes quickly or remains for several days after a heavy rainstorm.
4. Note whether the soil water depth gradually increases over the wet season or recedes after each storm. A gradual increase in water depth may indicate a serious drainage problem
5. If water gradually rises in your drainfield area during rainy periods, reduce water use that goes to the septic system. This can help alleviate soil saturation.
6. If sewage effluent surfaces in or near the drainfield area during or after heavy rain, contact an installer or the health department for further information.

Note: River or area flooding of a drainfield area is beyond the scope of this manual. These recommendations may be applied to locations that receive periods of high-intensity rain events that do not otherwise interfere with the use of the residence.

EMERGENCY OPERATION DUE TO POWER OUTAGES

Caution: *Any emergency operation plan that includes temporary emergency electrical power must comply with safety requirements. Contact your electric utility or local building inspection department that conducts electrical inspections, or the Washington State Department of Labor and Industries for requirements prior to any installation or use of a generator.*

Operation: If the water system continues to function during a power outage and the sewage system does not function due to power dependent components, the reserve volume in the system should be known. Pump chambers usually have some liquid capacity that can reasonably be used for temporary storage of effluent. This volume is very limited but can vary from a few hours to a few days capacity on a low water use plan. Limiting system use to occasional toilet flushing can maximize the amount of time until the tank is full. Excess use of the system during a power outage can cause solids to carry-over in systems that backups into the septic tank.

Note: If the system has accumulated water or effluent during a power outage, there could be a dangerously high volume of water that should not be delivered to the down-line components or drainfield in a single dose. Manual operation of the pump cycling may be necessary. Consult your design documents for system specifics and limits.

Monitoring: During power outage, monitoring ports, septic tank and pump chambers can be observed to avoid critical sewage or effluent levels in system components. Monitoring effluent levels during the power-on process is also recommended.

Maintenance: Physical maintenance is not applicable.

Landscaping. It is important and beneficial to your drainfield to landscape it with shallow rooted plants. These plants will help to take up nutrients and water in the drainfield. For more information see "Landscaping Your Septic System" by Washington Sea Grant, publication No. WSG-AS 98-02. Call 360-543-6600 for copies.

Risers. Tank risers are tubes made of metal, concrete or plastic, fixed to the tank top over the various tank lids to allow inspection, baffle cleaning, and septage removal. Risers allow observation of tanks without the repeated digging of soil cover. Making the joint between riser and tank watertight is important to prevent entry of water or loss of effluent. Risers save time and effort for emergency as well as periodic monitoring and maintenance.

Monitoring ports. They are highly advisable at locations where effluent would be temporarily stored during a power outage.

Surge tanks. When they provide larger temporary storage capacity, surge tanks may be advantageous in areas of frequent power outage. Adequate automatic controls or clear power-on instructions are essential.

Emergency power supply. Emergency power generators can be considered. Contact a licensed sewage system installer for further information. Care should be taken to know what electrical power needs apply to system components. (See "Caution" previous page).

APPENDIX A

GLOSSARY

Additive: A commercial product added to an on-site sewage system intended to affect performance or aesthetics of an on-site sewage system.

Approved: Acceptable by the health officer or department as stated in writing.

Aquifer: A geologic formation, group of formations, or part of a formation capable of yielding a significant amount of ground water to wells or springs.

Biological Filtration: The process of passing a liquid through a medium of a biological filter, thus permitting contact with attached biological films that adsorb and absorb fine suspended, colloidal, and dissolved solids, and release end products of biochemical action.

Biomat: The layer of active and inactive microbes and their extracellular products that accumulate upon the infiltrative surface at the bottom of effluent distribution trenches. The “clogging” action limits the hydraulic loading rate at which effluent can pass to the soil below.

Coarse Texture: The soil texture exhibited by sands, loamy sands, and some sandy loams, (not very fine sandy loam).

Coliform (bacteria): A group of bacteria that produce gas and ferment lactose, some of which are found in the intestinal tract of warm-blooded animals; used as an indicator of ground water and surface water pollution and sewage treatment efficiency.

Composting Toilet: Any device designed to store and compost by aerobic bacterial action human urine and feces, which are non-water carried, together with the necessary venting, piping, electrical and/or mechanical components.

Contamination: An impairment of natural groundwater quality by biological, chemical, or physical materials, which lower the water quality to a degree that creates a potential hazard to the environment, public health, or interferes with a beneficial use.

Disinfection: Killing or rendering pathogenic (disease causing) microorganisms incapable of reproduction or causing infection in a person or animal, while there may still be non-disease causing organisms still present.

Disposal Component: A subsurface absorption system or other soil absorption system receiving septic tank or other pretreatment device effluent and transmitting it to the location beyond further control or treatment, usually into original, undisturbed soil.

Dosing System: A system that allows for a dose-rest cycle within a conventional distribution system by means of a dosing tank and an automatic siphon, pump, or other type of dosing mechanism. The arrangement allows for the dosing tank to fill to a predetermined level at which point the siphon or pump discharges the volume to the drainfield.

Drainfield: An area in which perforated piping is laid in drain rock-packed trenches, or excavations (seepage beds) for the purpose of distributing the effluent from a wastewater treatment unit.

Drain Rock: Clean, washed, gravel. May vary in size from 3/4" to 2 1/2" in diameter; however, the gravel used must be of uniform size (uniformity coefficient 2), so void volume is at least 30%. Gravel is clean when clear water passed over a sample remains clear.

Effluent: Sewage, water, or other liquid, partially or completely treated or in its natural state, flowing out of a reservoir, basin, treatment plant, or septic tank.

Failure: The condition of an on-site sewage system that threatens public health by failing to adequately treat the sewage or by creating a potential for the public coming in direct contact with sewage. Example of failure include:

- ◆ Sewage on the surface of the ground;
- ◆ Sewage backing up into a structure caused by slow soil absorption of sewage;
- ◆ Sewage leaking from a septic system component;
- ◆ Cesspools or seepage pits where concerns exist for ground or surface water quality; or,
- ◆ Sewage contaminating ground or surface waters.

Fecal Coliform (bacteria): Coliform bacteria specifically originating from the intestines of warm-blood animals, used as an indicator of ground and surface water pollution and sewage treatment efficiency.

Filter: A device or structure for removing suspended solid or colloidal material from waste water.

Final Treatment/Disposal Unit: That portion of an on-site sewage system designed to provide final treatment and disposal of effluent from a wastewater treatment unit, including, but not limited to, absorption fields (drainfields), sand mounds, and sand-lined trenches.

Hardpan: A hardened or consolidated soil layer caused by cementation of soil particles. The hardness does not change appreciably when wetted by water. In Western Washington, hardpan is most frequently associated with glacial advance during previous ice ages.

High Strength Waste: Sewage waste from any sewage generating source whose concentration or strength is above usual residential waste.

Impermeable: A descriptive term for earth materials that have a texture or structure that does not permit fluids to perceptibly move into or through its pores or interstices.

Infiltrative Surface: In drainfields, the drain rock-original soil interface at the bottom of the trench; in mound or fill systems, the mound sand-original soil interface; in sand-lined trenches (sand filter), the sand-original soil interface at the bottom of the trench.

Influent: The water, waste water, or other liquid flowing into a reservoir, basin, or treatment plant, or septic tank.

Intermittent Sand Filter: A sand filter in which pretreated waste water is applied periodically providing intermittent periods of wastewater application, followed by periods of drying and oxygenation of the filter bed.

Invert: In pipe elevation measurement, the elevation of the bottom of the inside of the pipe.

Locking Lid: A lid that is child and tamper safe. The lid must be held down with bolts or other equivalent positive locking device.

Mottling: In soils, spots or blotches of reddish color on a gray background, or gray color in a predominantly reddish soil color. The mottled layer is used as an indication of high water table or saturated layer in soil.

Mound System: A method of on-site sewage treatment and disposal in which a specified sand filter media is laid on top of a properly prepared original soil surface. The distribution system and wastewater infiltration beds are then placed entirely within the filter media at such a level that the desired vertical separation to provide the necessary treatment exists. The original soil provides some additional treatment and is necessary to move the effluent away from the site without surfacing. Not included in this definition are systems where soil fill is used only for cover.

On-Site Sewage System: An integrated arrangement of components for a residence, building, industrial establishment, or other facilities not connected to a public sewer system which:

- (a) Convey, store, treat, and/or provide subsurface soil treatment and disposal on the property where it originates, upon adjacent or nearby property; and
- (b) Includes piping, treatment devices, other accessories, and soil underlying the disposal component of the initial and reserve areas.

Proprietary Device: A device or method classified as an alternative system, or a component thereof, held under a patent, trademark, or copyright.

Raw Waste Water: Waste water before it receives any treatment.

Recirculating Sand (Gravel) Filter: A sand (gravel) filter that processes liquid waste by mixing filtrate with incoming septic tank effluent and recirculating it several times through the filter media before discharge to a final treatment/disposal unit.

Residential Sewage: Sewage having the constituency and strength typical of waste water from single family households.

Residential Sewage Septic Tank Effluent: Effluent from a septic tank that is part of an on-site sewage system treating and disposing residential sewage. Residential sewage septic tank effluent quality is characterized by:

BOD₅: 230 mg/L (30 day arithmetic mean)

TSS: 150 mg/L (30 day arithmetic mean)

Riser: A vertical passageway from the top of a septic tank or pump chamber to the ground surface. Risers are intended to be of durable material, watertight, and have a durable mechanical connection to the tank it serves.

Sand Filter: A biological and physical wastewater treatment unit generally consisting of an underdrained bed of sand to which pretreated effluent is periodically applied. Filtrate collected by the underdrains is then disposed of by an approved drainfield system. Pretreatment can be provided by either a septic tank or another approved treatment device.

Sand-Lined Drainfield Trench (Sand Filter): A combination of a pressure distribution drainfield and an intermittent sand filter. A 2-foot layer of intermittent sand filter media placed directly below the drain rock layer in a drainfield trench combines the wastewater treatment of an intermittent sand filter with the direct-to-receiving soil discharge of a pressure distribution drainfield.

Septage: The liquid and solid contents of a septic tank, including all settled and floating materials.

Septic Tank: A watertight treatment receptacle that receives waste water from a building sewer or sewers, and is designed and constructed so as to permit separation of settleable and floating solids from the liquid, detention, facultative, and anaerobic digestion of the organic matter, prior to discharge of the liquid portion.

Sewage: Any urine, feces, or water carrying human wastes, including kitchen, bath, and laundry wastes from residences, buildings, industrial establishments, or other facilities. For the purposes of these regulations, "sewage" is generally synonymous with domestic waste water.

Solids: Materials in solid (not dissolved or vaporous) state.

Stratified Sand Filter: A sand filter that is constructed with various specific filter sand media, placed in horizontal layers of specified thickness, in sequential order, separated by supporting layers of gravel, also size-specified.

Surge Tank: A tank that collects treated waste water for a period of time and then, periodically, discharges it into another treatment or disposal unit, depending upon the needs and design of the particular on-site sewage system.

Treatment Component: Any approved method of, or device for, treatment of sewage, or part thereof, which may include collection, storage, and transference devices, such as pipe, pumps, pump chambers, drop boxes, etc.

APPENDIX B

ON-SITE SEWAGE LAWS AND REGULATIONS

Unsaturated Flow: The movement of water in or through soil that has not been filled to capacity with water. Water moving over soil particles, pulled by gravity, moving as a thickened film over soil particles.

Vault Privy: An enclosed nonportable toilet having a waste storage chamber that is water tight or installed in clay, bedrock, or other impermeable material.

Vertical Separation: The depth of unsaturated, original, undisturbed soil between the bottom of a disposal component and the highest seasonal water table, restrictive layer, or excessively drained soil. Vertical separation is also used in calculation of mound drainfield height and other constructed systems.

Waste Water: Water-carried human excreta and/or domestic waste from residences, buildings, industrial establishments, or other facilities.

Wastewater Design Flow: The maximum volume of waste water predicted to be generated by occupants of a structure. In many jurisdictions, i.e., for residential dwellings, this volume is calculated by multiplying the number of bedrooms by 120 gpd (gallons per day).

Water Table: The upper surface of the ground water, whether permanent or seasonal.

Well: Any excavation that is drilled, cored, bored, washed, driven, dug, jetted, or otherwise constructed when the intended use is for the location, diversion, artificial recharge, or withdrawal of ground water.

STATE STATUTES

Chapter 43.20 RCW (Revised Code of Washington) enables the Washington State Board of Health to adopt regulations pertaining to health and sanitation. This statute requires that all local public officials follow and enforce regulations adopted by the Board. The Board has adopted regulations pertaining to on-site sewage disposal in Chapter 246.272 WAC (Washington Administrative Code).

Chapter 70.05 RCW authorizes local boards of health to adopt regulations pertaining to health and sanitation, requires that a health officer be appointed and charges the health officer or his/her authorized representative to enforce such regulations. This statute also authorizes the health officer to take such actions as are necessary for the maintenance of sanitation and public health.

STATE REGULATIONS

Chapter 246-272 WAC, as cited above, sets standards for on-site sewage treatment and disposal, requires that permits for on-site systems be issued, and requires the approval of installers, pumpers, designers, and maintenance personnel.

WAC 246-272-15501 states that the system owners are responsible for: operating and maintaining their systems; determining levels of sludge and scum in their septic tanks once every three years; employing approved pumpers to remove solids when necessary; protecting their drainfield and reserve areas from cover by impervious materials, surface drainage, soil compaction by vehicle traffic, damage by soil removal or grade change; keeping the flow of sewage at or below the approved levels of quantity or strength; operating their systems as directed by the health officer; and directing drains away from the drainfield area.

WAC 246-272-15501 further states, in part, that the health officer shall provide operation and maintenance information to owners and initiate monitoring of each on-site system no later than January 1, 2000.

LOCAL REGULATIONS

Local boards of health are empowered to adopt local regulations in conformance with state laws and regulations.

Copies of pertinent regulations may be obtained from the County Health Department, Environmental Health Division. There may be a fee for such copies.

APPENDIX C

ON-SITE SYSTEMS, LIFE CYCLE, ROLES, AND RESPONSIBILITIES

One way to understand on-site sewage treatment and disposal systems is to trace their life. That is, how systems come to exist, who plays various roles at different stages, and who has authority and responsibility for varied actions.

Individual system planning begins when an owner decides to build. The size and placement of a residence is drawn up and a general contractor is called. Together the **owner and builder lay out the house, garage, driveway, utilities routing, and preliminary locations for the on-site system and reserve area.** At this point a designer may be called to evaluate the tentative locations of installation and reserve areas. **Test holes** are dug in proposed drainfield and reserve areas to evaluate soil quality, depth to water table or impermeable materials, and determine drainfield size. The **designer formulates a system design** that would handle the sewage generated from a residence of the chosen size. **The design is reviewed** for compliance with sewage code standards by the health department environmental health specialists. Depending on the complexity of the approved design and regulations that apply to system types, an operation and maintenance manual may be required as part of the review and approval. When all is in order, **installation permits are issued.** A **licensed installer or contractor installs the system.** The **system is inspected and approved for use.** When the residence is completed and occupied, system use or “**operation**” is begun.

During the years of operation, **monitoring** of system function is performed by the homeowner and qualified personnel. **Maintenance is scheduled and performed** routinely. **If or when component failure is detected, repair is performed.** On-site systems are commonly operated with monitoring, maintenance, and minor repair, without major system failure, for 20 to 30 years.

Advances in on-site sewage treatment technology over the last three decades have allowed the development of on-site systems that treat waste water to a degree roughly equivalent to good municipal treatment facilities. In many cases higher technology systems have been employed to overcome native soil difficulties or to repair systems discharging waste water into fresh or marine waters. **Systems of higher complexity usually require a higher degree of monitoring and maintenance to achieve their full treatment potential.** Necessary component maintenance should not be regarded as failure. Temporary failure can occur when systems are not operated, monitored, or maintained as necessary.

INDIVIDUAL AND ORGANIZATIONAL ROLES

An on-site system could involve many of the following actions and participants, beginning before a lot is created. Laws and practices and the state of the art technology at the time of the event determine the nature of the actual events.

1. COMMUNITY PLANNING

Communities, through land use and utility planning processes, decide where land uses may be placed and where sewers or on-site treatment and disposal system are to be used. The creation or subdivision of lots for building is done to community standards and review process. The county or city planning departments plays a key role.

2. INDIVIDUAL LOT PLANNING

When a residence is initially built, the owner and his/her general contractor do most of the lot development planning. On-site designers participate in lot planning to assure residence, water system, and sewage system location compatibility.

3. SITE EVALUATION

Lots or tracts that will have an on-site system are evaluated by designers and the health department for soil and system type acceptability. Soil type and texture, permeable soil depth, slope, drainage characteristics, locations of surface water, water wells and neighboring facilities and utilities must be determined before a system can be designed.

4. SYSTEM DESIGN

On-site designers formulate system design proposals to meet the needs for construction proposals, and to meet legal standards for separation from surface water, water wells, water lines, the protection of ground water, and many other necessary features.

5. INSTALLATION

Licensed installers or installation contractors construct on-site systems. They have the equipment and experience to carefully install systems without damaging soil permeability, and can determine from design plans how the system will function when complete.

6. OPERATION

System owners and users determine how a system is operated. Owners make the decisions that determine the amount of use and their actions control the inputs to the system.

7. MONITORING

Homeowners have the responsibility for monitoring or having their systems monitored by licensed professionals. This is primarily based on the requirements that apply to specific system types. For details contact the local health department.

8. MAINTENANCE

Maintenance must be performed by qualified, certified people. The health department certifies installers, pumpers, and certified maintenance specialists for various levels of maintenance. For details contact the local health department.

9. REPAIR

Major repairs must be performed by licensed personnel. Minor repairs may be performed by unlicensed personnel. Contact the local health department for further information.

10. REGULATION/LEGAL ENFORCEMENT

In Washington State, the rules and regulations of the State Board of Health (WAC 246-272) set primary standards for on-site sewage systems, treatment, and disposal. The local Board of Health has the authority to adopt local regulations. Such regulations must be as stringent as the state regulations. All local officials are obligated by statute to enforce the regulations of the State Board of Health.

11. FINANCING

Most financing of on-site system construction, repair, monitoring, and maintenance is paid by the property owner, on a fee-for-service basis. In recent years, low interest rate loan programs have been created to enable some system repairs. Contact the local health department for further information.

12. PUBLIC EDUCATION

On-site system education is distributed among University of Washington (UW), Washington State University (WSU), the Washington On-site Sewage Association (WOSSA), the Northwest On-site Waste Water Training Center, the Washington State Department of Health (DOH), and local health departments. The media carry public service announcements and informa-

tional articles as well.

RESPONSIBILITIES

The homeowner has the primary authority and responsibility to control actions related to their on-site sewage system. The owner has the best authority to control what goes into the system and needs no external authorization to monitor the function of system components, and can perform or hire (when required) licensed persons to perform all legally acceptable functions. They also have the use of the property under control.

The homeowner also has the responsibility for the successful function of the on-site system. It is the property owner that holds the responsibility for the prevention of health hazards, the prevention of water pollution that can come from the sewage system and financial responsibility to insure proper functioning.

In Washington State, as in most states, the owner has the greatest scope of property rights and the responsibilities that go with them.

Designers are certified by the local health department, and are thus authorized to evaluate property, propose design solutions to sewage disposal problems, and are obligated to design systems that comply with minimum standards set by state and local regulations that apply to sewage disposal. Circumstances may exist when it would be wise for a property owner to instruct the designer to exceed the minimums for better or longer performance.

Installers, or on-site sewage system (OSS) contractors, are certified by the local health department and are authorized to install sewage systems that have been approved by the OSS permitting process. Grave damage can be done to the soil's internal drainage characteristics if the approved sewage system plan or design is not installed correctly. Damage to the soil's internal drainage characteristics can also be done by vehicles, equipment, or materials stored on the site. The installer is also required to be licensed as a general or specialty contractor by the Department of Labor and Industries.

Septic tank pumpers are certified to perform sludge removal and are obligated to deliver septic sludge to approved disposal locations.

Certified maintenance specialists are certified to make monitoring observations and submit reports in accordance with local health department regulations.

APPENDIX D

REFERENCES

Chapter 246-272 WAC, On-Site Sewage Systems. Rules and Regulations of the State Board of Health, adopted March 9, 1994, effective January 1, 1995. Washington State Department of Health, Office of Community Environmental Health Programs, Building 2, Thurston Airdustrial Center, PO Box 47826, Olympia, WA 98504-7826.

Controls and Sensors for On-Site Treatment Systems. March 17, 1995. Terry R. Bounds, P.E. V.P. Orenco Systems, Sutherlin OR, 97479.

Design Manual, On-site Wastewater Treatment and Disposal Systems. October 1980. EPA 625/1-80-012. U.S. Environmental Protection Agency, Office of Water Program Operations, Office of Research and Development, Municipal Environmental Research Laboratory.

Design Standards for Large On-Site Sewage Systems with Design Flows of Greater than 3,500 Gallons per Day. December 1993, amended July 1994. Washington State Department of Health, Office of Community Environmental Health Programs, Building 2, Thurston Airdustrial Center, P.O. Box 47826, Olympia, WA 98504-7826.

Diagnostic Techniques Utilized in the Analysis of Failed Systems for Residential Waste. February 15, 1994, William L. Stuth, Stuth Co. Inc. PO Box 950, Maple Valley, WA 98038-0950 Lecture Notes from the Appropriate Technology Workshop # 1, presented by Washington On-Site Sewage Association.

Guidelines for Aerobic Treatment Systems. July 1984, revised July 1990. Technical Review Committee. Washington State Department of Health, Office of Community Environmental Health Programs, Building 2, Thurston Airdustrial Center, P.O. Box 47826, Olympia, WA 98504-7826.

Guidelines for Mound Systems. November 1986, Revised September 199. Technical Review Committee. Washington State Department of Health, Office of Community Environmental Health Programs, Building 2, Thurston Airdustrial Center, P.O. Box 47826, Olympia, WA 98504-7826.

Guidelines for Sand Filters. June 1996. Technical Review Committee. Washington State Department of Health, Office of Community Environmental Health Programs, Building 2, Thurston Airdustrial Center, P.O. Box 47826, Olympia, WA 98504-7826.

Interim Guidelines for the Application of Treatment Standards 1 and 2, using Alternative On-site Sewage Treatment/Disposal Systems November 10, 1989, amended August 4, 1992. Washington State Department of Health, Office of Community Environmental Health Programs, Building 2, Thurston Airdustrial Center, P.O. Box 47826, Olympia, WA 98504-7826.

List of Approved Systems and Products. As Established in Chapter 246-272 WAC, On-Site Sewage Systems. September 30, 1998. Washington State Department of Health, Office of Community Environmental Health Programs, Building 2, Thurston Airdustrial Center, P.O. Box 47826, Olympia, WA 98504-7826.

Manual of Septic Tank Practice. Publication No. 526, U.S. Public Health Service, Washington DC, 1967.

Operating and Maintaining the Home Septic System. Don D. Jones, Ext. Ag. Eng. and Joseph Yahner, Ext. Agronomist, July 1982.

Thurston County Septic Tank Pumpers' Manual. June 1992, revised March 1993. Environmental Health Division, Thurston County Public Health and Social Services, 2000 Lakeridge Drive SW, Olympia, WA, 98502.

Note: All Washington State Department of Health Guidelines and publications that result from content of the State Board of Health regulations, can be obtained by contacting the environmental health division of local county and district public health departments.